

ROTARY R.E. UNION

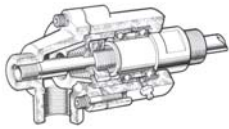



ROTARY (R.E.) UNIONS

1/4" to 1-1/4"

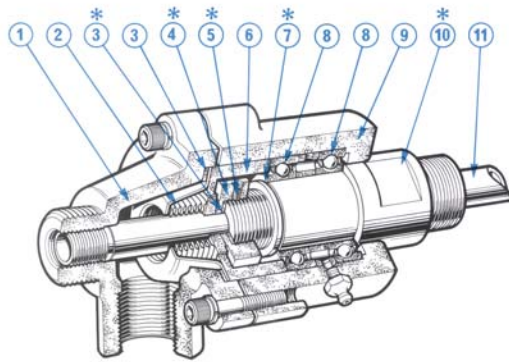

* Note: The components indicated by (*) rotate with the machine shaft.

Rotary (R.E.) Union - Type S.T.

1. Adaptor, high quality cast-iron
2. Bellows sub-assembly, brazed stainless steel
3. Gaskets
4. Seal ring sub-assembly, steel / carbon
5. Locking screw, heat treated steel
6. Spacer
7. Circlip
8. Ball bearings
9. Body - high quality cast iron
10. Rotary spindle, steel
11. Centre tube (if ordered)

Description

The rotary R.E. union is a self-contained, self-supporting rotary seal for the leak-proof transfer of fluids such as steam, water, air and oil to and from rotating machine shafts. The type of rotary seal fitted to this model is a Filton® Bellows Seal containing a flexible stainless steel bellows which is self-adjusting, eliminating the maintenance common with conventional packed glands. Rotary sealing is created by relative rotation between extremely flat sealing faces (see item #2 and #4 in diagram above) held in contact by the spring characteristics of the bellows combined with an additional sealing force created by the pressure of the fluid passing through the rotary union. The bearings fitted to the union are standard ball bearings which are supplied with the initial lubrication completed prior to shipping. There are three variations of the stationary adapter end:

1) Type B.E. - Single Flow

A single flow union suitable for transferring fluid in to or out of rotating machines.

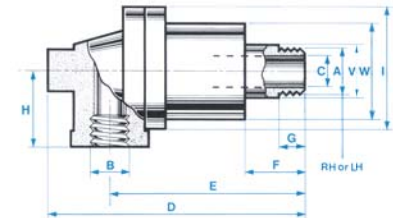

Type B.E.

2) Type S.T. - Double Flow (Stationary Center Tube)

Fitted with an adapter suitable for double flow with a stationary center tube. This gives flow areas through the center tube and annulus. The center tube - provided only if ordered - is fixed to the union end by means of a screw thread (dimension "O"). Flow can pass in through the center tube and return through the annulus or be reversed. For steam applications, the center tube is curved to reach the condensate in the bottom of the cylinder. If the roll neck diameter to length ratio prevents the use of a curved tube, a syphon elbow can be specified instead. See the Accessory Section or contact us for more information about the options available.

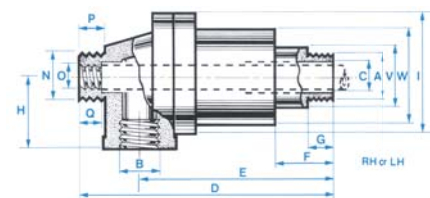

Type S.T.

3) Type R.S. - Double Flow (Rotary Center Tube)

Fitted with an adapter suitable for a rotating center tube which must be located and driven by the machine. The center tube - provided only if ordered - rotates in a bush. Flow can pass in through the center tube with the return through the annulus or be reversed. The center tube "sealing" system allows for a slight internal leakage between the supply and return lines. If these fluids must not mix, alternate designs are available. Please contact us for additional information.

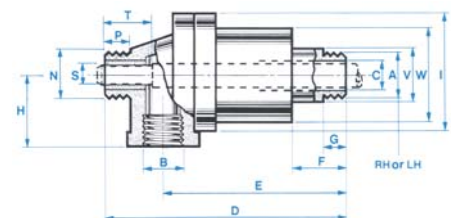

Type R.S.

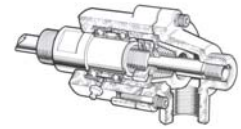

Model and Dimensional Information

Nominal Size	Rotary (R.E.) Union - Model Part Number			Dimensions (mm unless specified otherwise)													
	B.E. (R or L)	S.T. (R or L)	R.S. (R or L)	A, B, N ⁽ⁱ⁾	C	D	E	F	G, P	H	I	O	Q	S	T	V	W
8 (1/4")	14642	14643M	17196	G. 1/4"	6	117	94	22	11	30	57	M5 x 0.8	6	4.75 / 4.72	25	24	44
10 (3/8")	14636	14637M	17197	G. 3/8"	10	121	97	25	13	30	57	M6 x 1.0	6	6.35 / 6.32	25	24	44
15 (1/2")	14536	14535	16657	G. 1/2"	13	167	130	29	16	44	83	G. 1/8"	6	9.52 / 9.50	40	38	63
20 (3/4")	14460	14534	16659	G. 3/4"	18	173	133	32	19	44	83	G. 1/4"	10	12.70 / 12.67	40	38	63
25 (1")	14396	14542	16661	G. 1"	22	197	149	48	22	54	105	G. 3/8"	10	15.87 / 15.85	45	43	83
32 (1-1/4")	14377	14379	16663	G. 1-1/4"	30	227	170	51	25	70	121	G. 1/2"	13	19.05 / 19.02	50	55	95

⁽ⁱ⁾ "G" is the designation for parallel pipe threads to BS.2779 and ISO 228/1.

Flow Capacity

Nominal Size	Rotary (R.E.) Union - Model	Water ⁽ⁱⁱ⁾		Steam ⁽ⁱⁱⁱ⁾	Air ^(iv)
		m ³ /h	l/min	kg/h	m ³ /h
8 (1/4")	B.E.	0.3	5.0	11	11
	S.T. / R.S.	0.05	0.8	3.4	2
10 (3/8")	B.E.	0.8	13.3	31	29
	S.T. / R.S.	0.1	1.7	16	4
15 (1/2")	B.E.	1.7	28.3	61	58
	S.T. / R.S.	0.3	5	27	10
20 (3/4")	B.E.	2.7	45	101	96
	S.T. / R.S.	0.6	10	41	22
25 (1")	B.E.	4.1	68.3	151	144
	S.T. / R.S.	1.8	30	56	44
32 (1-1/4")	B.E.	7.6	127	280	267
	S.T. / R.S.	2.1	35	133	74

⁽ⁱⁱ⁾ Flow measured in cubic metres/hour at a velocity of 3 metres/second. (Also applies to other liquids.)

⁽ⁱⁱⁱ⁾ Flow in kilograms/hour at a velocity of 30 metres/second and a pressure of 6 bar.

^(iv) Flow in cubic metres/hour free air at a velocity of 15 metres/second and a pressure of 6 bar.

Maximum Operating Recommendations

Fluids: Water, steam, mineral oils and compressed air (lubricated).
All fluids should be clean and free from abrasive particles.

Pressure: 17 bar maximum.

Vacuum: 740mm Hg. maximum (specify vacuum and we will test for this).

Temperature: -20°C to 180°C (and up to 200°C with special lubrication).

Speed: 1000 r.p.m. maximum for sizes up to 25 (1") and 800 r.p.m. maximum for sizes above.

Storage: Store indoors in a dry area between the temperature ranges of -10°C to 30°C.

*** Note:** It is not advisable to exceed or combine maximums.

Installation Procedures

- 1) A suitable run-in period before fitting is recommended. Rotate the R.E. at 300 r.p.m. for 15 minutes.
- 2) Add system liquid if seals squeak.
- 3) A torque arrestor may be fitted, but this must not restrict the rotary union.
- 4) Ensure that the spindle thread is RH or LH to suit the direction of rotation of the machine shaft.
- 5) If the machine shaft reverses direction of rotation, securely lock the spindle or (preferably) use a flanged connection.
- 6) DO NOT fix valves etc. directly on to the rotary union.
- 7) DO NOT connect with rigid pipe.
- 8) DO NOT clamp the rotary union.

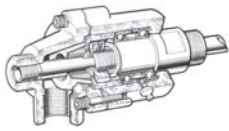

ROTARY (R.E.) UNIONS

1/4" to 1-1/4"

Installation (Continued)

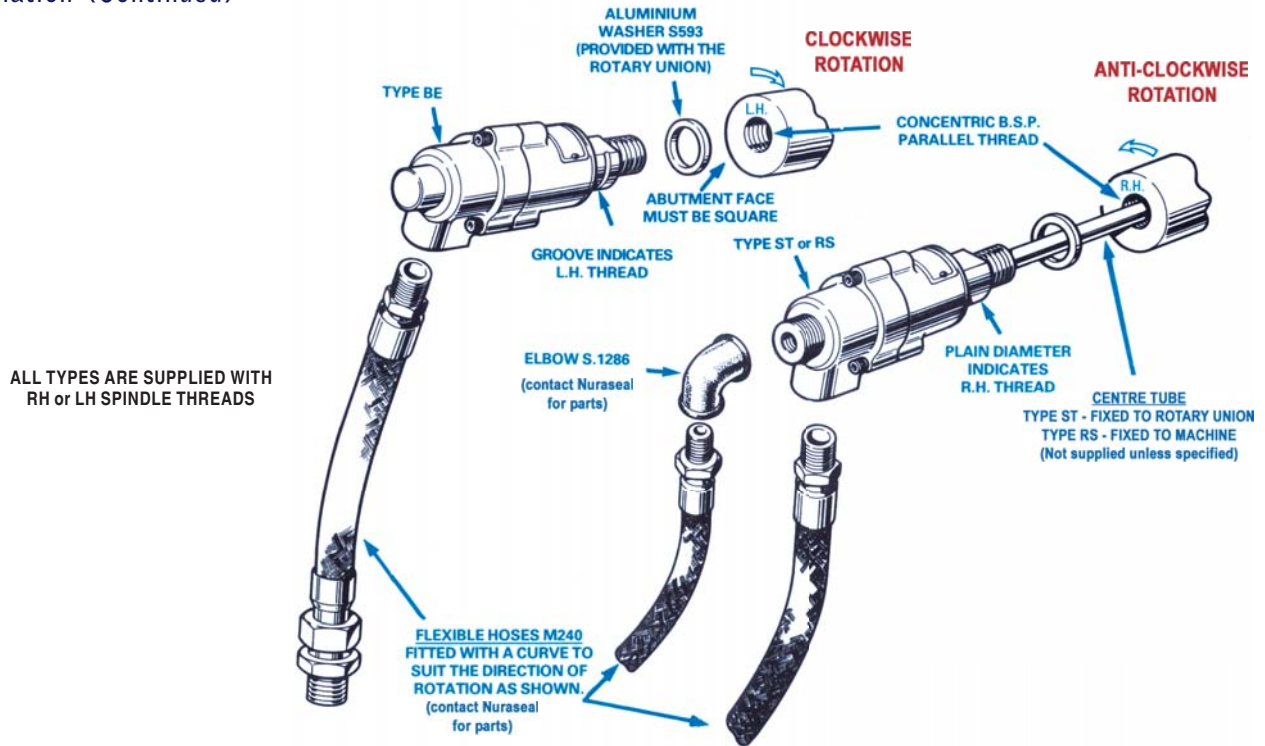

Part Identification

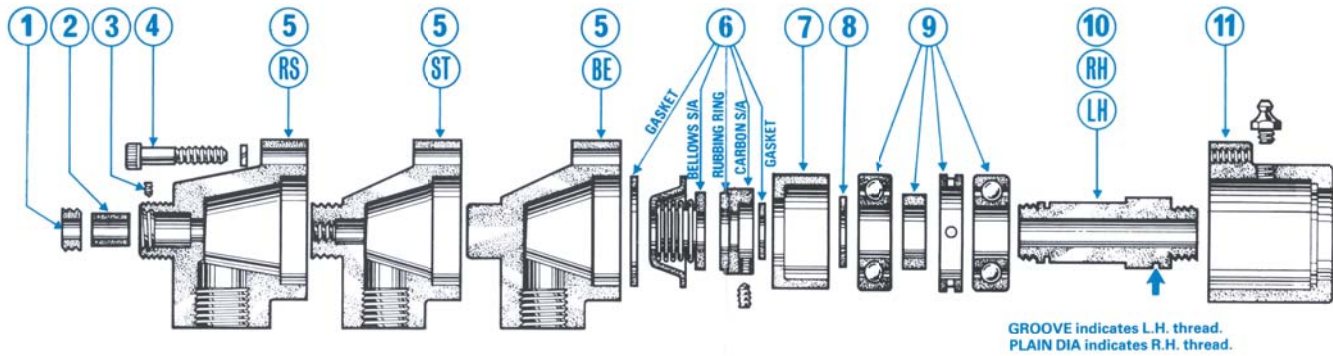

Nominal Size	1	2	3	4	5 - Adapter			6	7	8	9	10	11
	Retainer	C/T Bearing	Screw	Bolt	B.E.	S.T.	R.S.	Seal Kit	R.E. Spacer	Circlip	Bearing Kit	R.E. Spindle (R.H. or L.H.)	R.E. Body
8 (1/4")	not used	17196/2 ^(v)	not used	3/16" BSF or M5	14642/1	14643/1	17196/1	S.1100/1	14636/6	M.184/2	S. 1234/1	14642/2	14636/2
10 (3/8")	not used	16265/9 ^(v)	not used	3/16" BSF or M5	14636/1	14637/1	17142/1	S.1100/1	14636/6	M.184/2	S. 1234/1	14636/3	14636/6
15 (1/2")	16657/3	16657/2	6 B.A.	1/4" BSF or M6	14536/1	14525/1	16657/1	S.1100/2	14534/3	M.184/3	S. 1234/2	14535/1	14534/1
20 (3/4")	16659/3	16659/2	6 B.A.	1/4" BSF or M6	14524/1	14523/1	16659/1	S.1100/2	14534/3	M.184/3	S. 1234/2	14534/2	14534/1
25 (1")	16661/3	16661/2	M3 x 0.5	5/16" BSF or M8	14396/1	14386/1	16661/1	S.1100/3	14396/3	M.184/4	S. 1234/3	14396/4	14396/2
32 (1-1/4")	16663/2	16663/3	M4 x 0.7	3/8" BSF or M10	14377/1	14488/1	16663/1	S.1100/4	14377/8	M.184/5	S. 1234/4	14377/3	14377/2

^(v) Press Fit in Adapter.

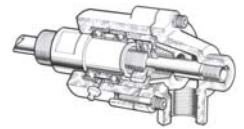

Maintenance and Overhaul

- 1) Remove bolts and washers (4) which allow for the removal of the adapter (5) and body (11).
- 2) Remove the bellows subassembly and the gasket of the seal kit (6).
- 3) Remove locking screws and unscrew the carbon subassembly (R.H. thread) of the seal kit (6).
- 4) Remove the spacer (7).
- 5) Thoroughly clean and check the ball bearing kit (9). Re-lubricate using an approved grease. If there is any doubt about the bearing condition, replace it by removing circlip (8) and then pressing-off the bearing kit.
- 6) If the adapter (5) is Type R.S., remove the locking screw (3), unscrew the locking ring (1) and remove the C/T bearing (2).
- 7) Replace seal kit (6), bearing kit (9) and if Type R.S., C/T Bearing (2). Handle the seal kit with care to avoid damaging the lapped seal faces.
- 8) Thoroughly clean all parts before reassembly (which is virtually the reverse of the above steps).
- 9) After reassembly, follow the recommended installation procedures and allow for a suitable run-in period to ensure the seals are working correctly before refitting to the machine.

Minimum Length for Flexible Hose

Nominal Size	Length (mm)	Part Number
8 (1/4")	150	M.240/1
10 (3/8")	230	M.240/2
15 (1/2")	305	M.240/3
20 (3/4")	305	M.240/4
25 (1")	380	M.240/5
32 (1-1/4")	460	M.240/6

Lubrication

The bellows seal fitted to the rotary R.E. union is self-adjusting within its working life. The ball bearings are lubricated prior to shipping with a Bentone-base grease and occasionally require re-lubrication with a compatible grease; generally once per shift on "hot" applications and once per month on "cold" applications. For more specific recommendations, contact the grease manufacturer. Recommended lubricants include:

BARDAHL

Multipurpose Grease #2 -20°C / +160°C
Haute Temperature -10°C / +180°C

BP

Energerease LS2 -30°C / +130°C
Energerease HTG2 -20°C / +180°C

BURMAH-CASTROL

Spheerol MP3 -40°C / +120°C
Spheerol B2 -25°C / +180°C

DOW CORNING

Molykote 44M -40°C / +180°C

ELF OIL

Multi 2 -25°C / +130°C
Staterma GB3 -10°C / +180°C

ESSO

Beacon 2 -25°C / +125°C
IL 2880 -20°C / +180°C

KLÜBER

Centoplex 2EP -20°C / +130°C
Petamo GHY443 -25°C / +180°C

MOBIL

Mobilplex 47 -25°C / +150°C
Mobiltemp 1 +10°C / +180°C

ROCOL LTD.

Sapphire 2 -30°C / +150°C
Saphire Hi-Temp 2 -40°C / +180°C

SHELL

Alvania EP LF2 -20°C / +120°C
Darina Grease R2 +10°C / +190°C

TEXACO

Multifak AFB2 -40°C / +120°C
Starfak Ultratemp 2 -40°C / +175°C

*** Note:** For subzero temperatures, please contact Nuraseal to ensure the model is suitable for the working conditions.

For nearly three decades, Nuraseal has been providing sales and service for all Filton® Rotary Union Products. Whether you require new or custom unions, replacement components, technical support or assistance with maintenance inquiries, Nuraseal will be able to help you solve your application requirements throughout North America and abroad. Contact us to find out how we can help you today!

Need Help? Here's what to do before you call. . . **Toll Free ! 1-888-NURASEAL (687-2732)**

In order to better serve your needs, it is helpful to collect some basic information prior to contacting us. Most of this information will be located on a plate fastened to the unit itself or easily identified by visual inspection.

- Rotary Union Model type i.e. Rotary R.E. Union
- Part number i.e. 16663.
- Serial number - generally identified either by a combination of two letters followed by four numbers or four numbers followed by a single letter i.e. ZN5631
- Nominal size
- Direction of rotation - if there is a groove in the spindle, it is a left-hand thread.

Other information that is helpful, especially when trying to select a suitable model or when troubleshooting during times of maintenance or unit failure, include:

- Type of fluid, flow rate, pressure, temperature
- Ambient temperature
- Rotational speed
- Working cycle
- Any unusual conditions i.e. exposure to harsh environments, etc.

Quick Selection and Reference Guide

Check the Application Requirement column below for the appropriate fluid and size range. Turn to the page for the model indicated and check the full working conditions and limitations. If more than one model is indicated, examine the application information on the appropriate pages. Contact us for more information.

Air	Application Requirements							Rotary Union Model Type	Available Size Range ⁽¹⁾
	Gas ⁽³⁾	Oil (Lubricating)	Oil (Hydraulic)	Oil (Heat Transfer)	Steam	Vacuum	Water		
Y ⁽²⁾	Y	Y	--	Y	Y	Y	Y	R.E.	8 (1/4") - 32 (1 1/4")
Y ⁽²⁾	Y	Y	--	--	--	Y	Y	P.B.	15 (1/2") - 25 (1")
Y ⁽²⁾	Y	Y	--	Y	Y	Y	Y	R.E.B.	40 (1 1/2") - 150 (6") ⁽⁵⁾
--	--	--	--	Y ⁽⁴⁾	Y	--	Y	C.B.	8 (1/4") - 32 (1 1/4")
--	--	--	--	Y ⁽⁴⁾	Y	--	Y	C.B.N.	40 (1 1/2") - 150 (6") ⁽⁵⁾
Y ⁽²⁾	--	Y	--	--	--	--	Y	L.C.	8 (1/4") - 20 (3/4")
Y	--	--	--	--	--	Y	--	P.N.	8 (1/4") - 20 (3/4")
Y ⁽²⁾	Y	Y	Y	--	--	Y	--	M.C.T.	8 (1/4") - 25 (1")
Y ⁽²⁾	--	Y	Y	--	--	Y	Y	I.N.T.	8 (1/4") - 25 (1")

Legend:

- (Y) Suitable for your application, but check the working condition information
- (1) Size range as measured at the rotary spindle connection end
- (2) Lubricated air only (if air is dry and P.N. model is unsuitable, special seals are available)
- (3) Depends on type of gas and working conditions
- (4) Flanges may be required depending on the working conditions
- (5) Flanges may be fitted to assist for removal and maintenance on sizes 100 (4") and larger.

ALSO AVAILABLE



Swivel Joints



Mechanical & Specialty Seals



Air Breather Filters



996-B5 Westport Cres.
Mississauga, Ontario CANADA
L5T 1G1

Phone: (905) 795-8380
Fax: (905) 795-8381

Toll Free:
1-888-NURASEAL (687-2732)

www.nuraseal.com
info@nuraseal.com